



ELECTRICITY



UNIVERSITY OF GEORGIA
EXTENSION
Athens-Clarke County



WHAT IS ELECTRICITY?

The flow of electrical power or charge.

Electricity is also referred to as an energy carrier.

**We can collect electricity from
the conversion of various forms of energy**



FORMS OF ENERGY

Light

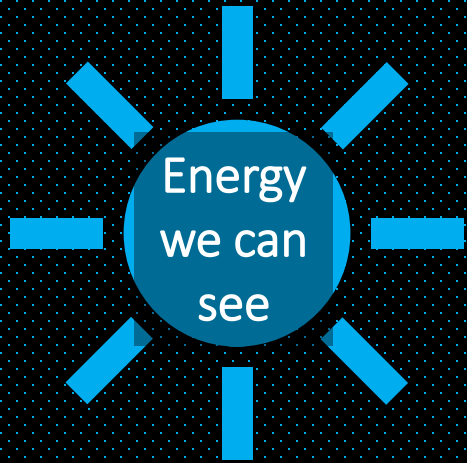

Sound



Thermal

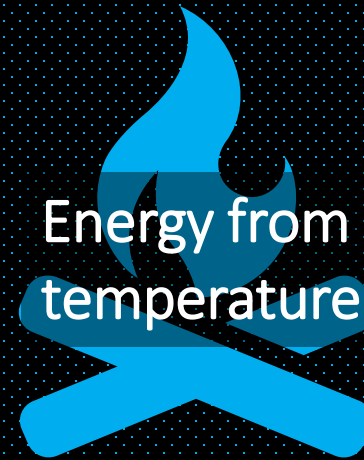

Mechanical

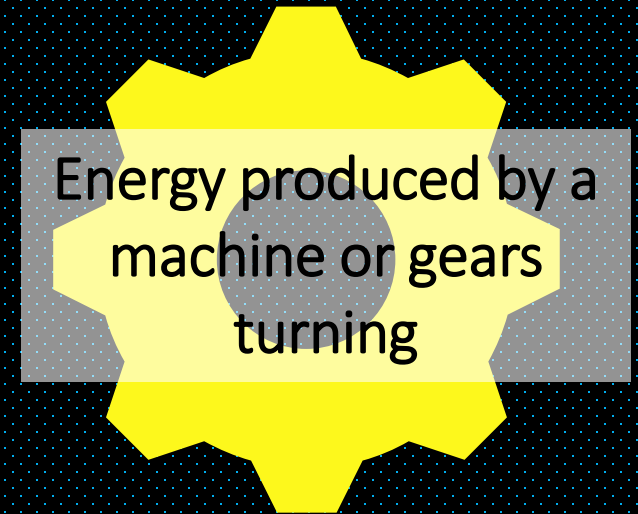

Electrical

Chemical energy from a battery (energy from the flow of electrons)

HOW DO WE USE ELECTRIC CHARGE?

Electric charge maybe transferred either by direct contact or by passing through a conducting material



CONDUCTORS AND INSULATORS FOR ELECTRICAL ENERGY

CONDUCTORS

A material or device that transmits electricity

What are some examples of Conductors?



INSULATORS

A material or device which does not readily transmit electricity

What are some examples of Insulators?



CONDUCTORS AND INSULATORS FOR ELECTRICAL ENERGY

CONDUCTORS

A material or device that transmits electricity

- **ALUMINUM**
- **COPPER**
- **IRON**
- **STEEL**
- **WATER**



INSULATORS

A material or device which does not readily transmit electricity

- **GLASS**
- **RUBBER**
- **PLASTIC**
- **WOOD**
- **PAPER**
- **COTTON**



CIRCUITS

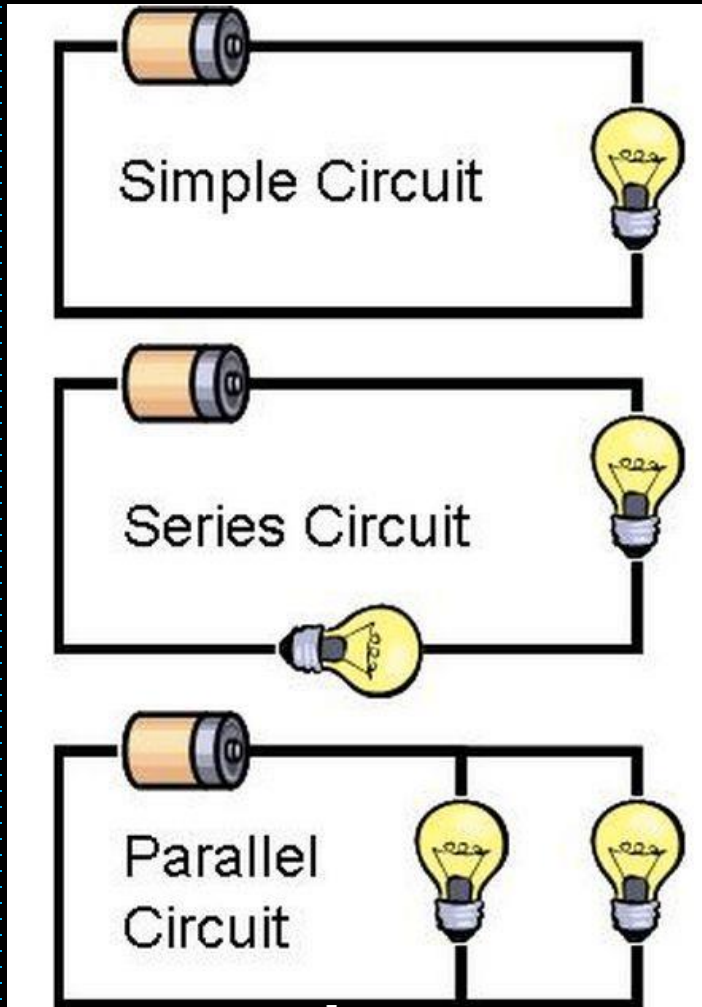

Current runs through one line and flows through one component

Current runs through one line and flows through multiple components

Current runs through lines that are arranged parallel to one another and flows through multiple components



CIRCUITS

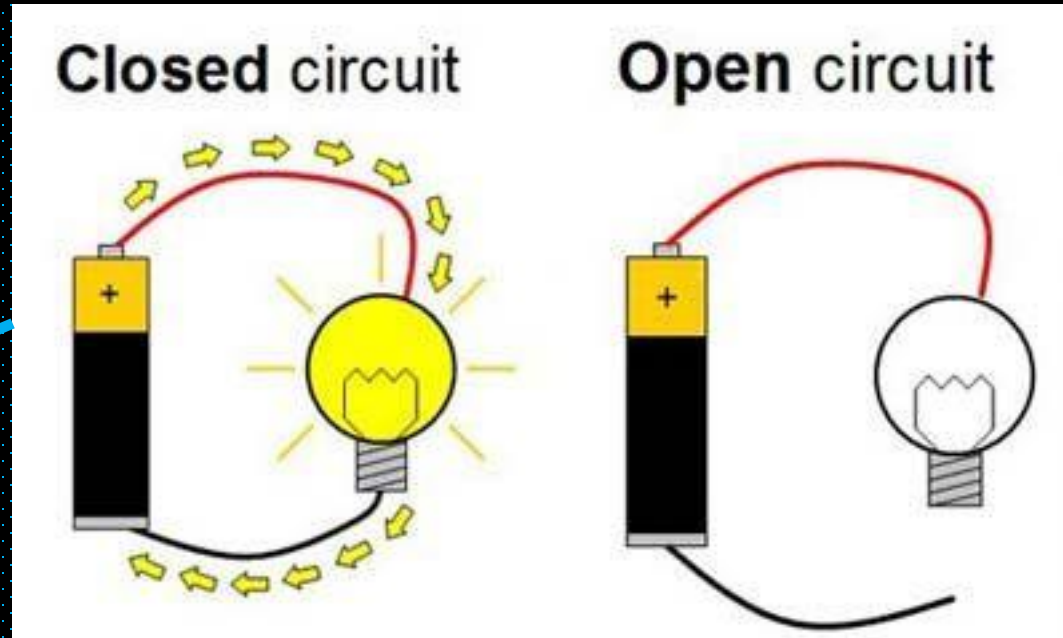

Makes a complete path for the flow of energy to pass through

Makes an incomplete path for the flow of energy



ALTERNATIVE SOURCES OF ENERGY

Solar



Wind



UNIVERSITY OF GEORGIA
EXTENSION
Athens-Clarke County



Hydroelectric



Hydroelectric Power System

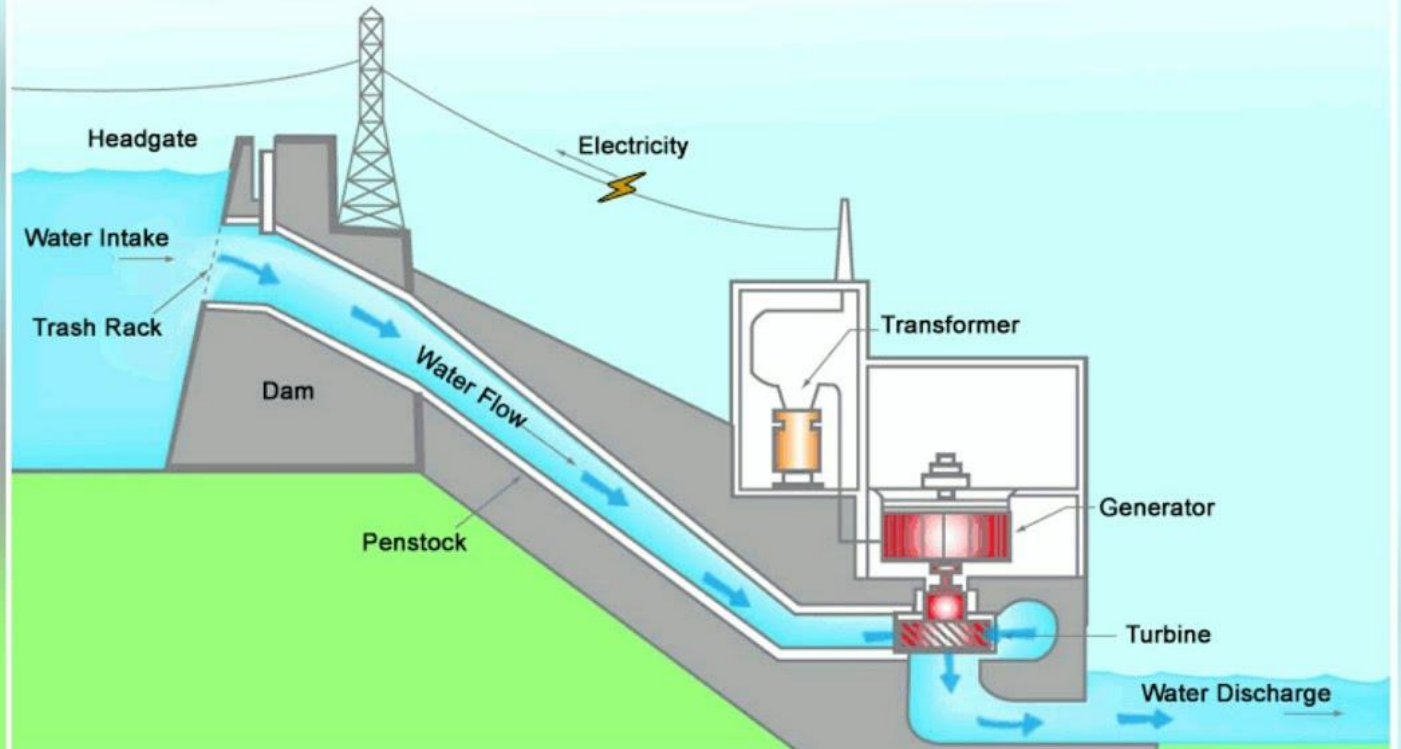

LET'S MAKE A SIMPLE CIRCUIT !!

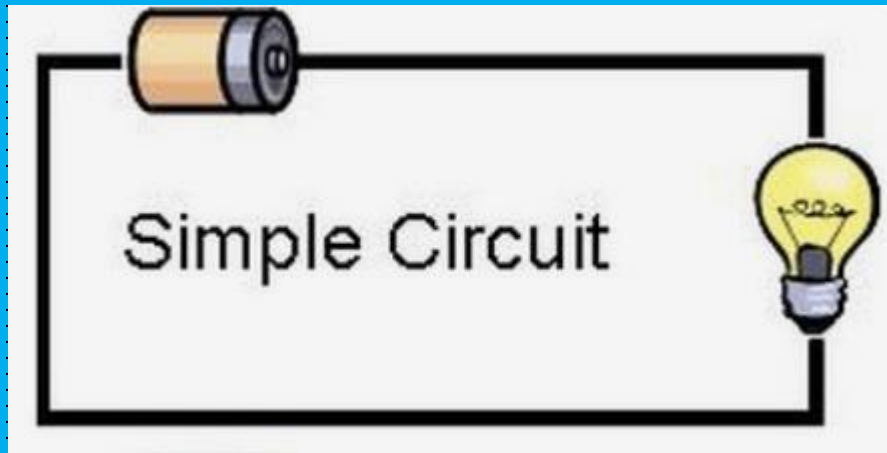

Materials

- 1 String Light
- Aluminum Foil
 - Tape
 - Paper
- Battery

SIMPLE CIRCUIT

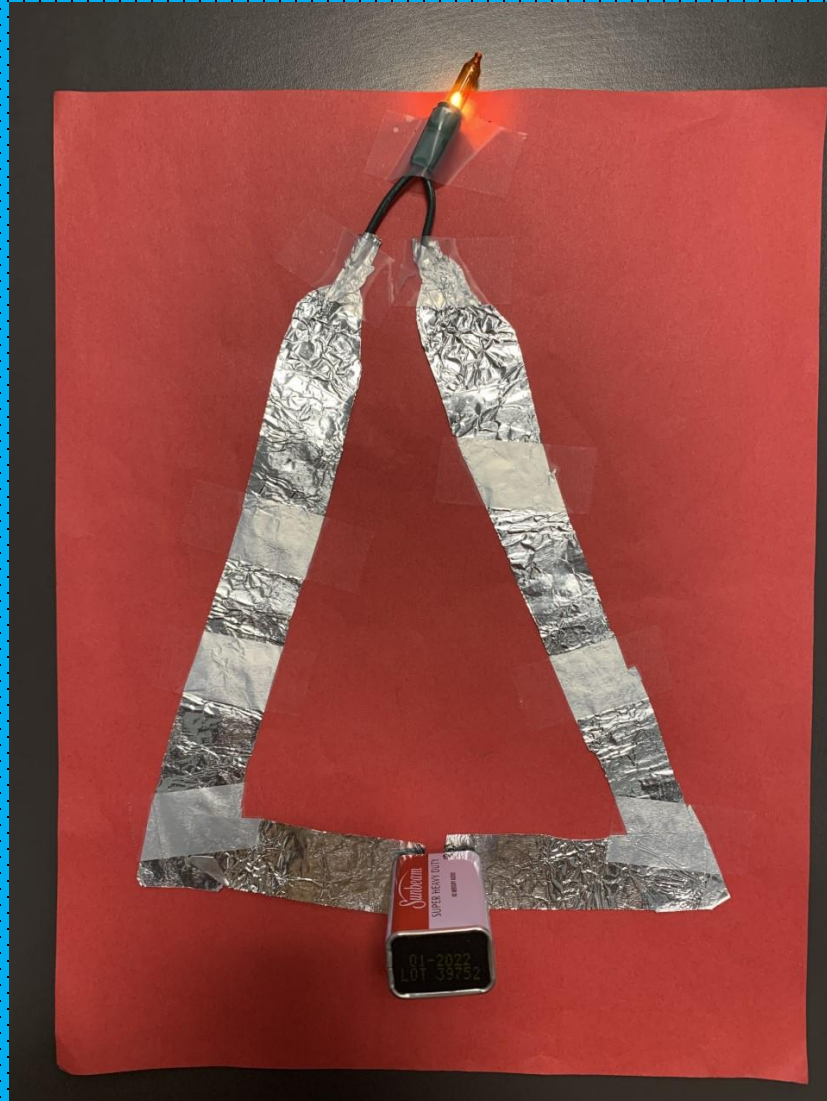

MilkMake Recipe Contest

The dairy industry is an important part of Georgia agriculture. There are currently 200 dairy farms in Georgia that produced over 206 million gallons of milk last year. Milk and milk products are an important source of calcium in our diets. Let's get creative and see if you can create a recipe for a milk shake or smoothie.



Here are a few simple rules:

1. Find or make up a recipe for a milk drink. It must have milk as one of the ingredients.
2. Write out the complete recipe. Make sure it has a title, list of ingredients, and a description of how to make your drink. Be sure to put your name on your recipe.
3. Make the drink following your directions.
4. Have someone taste it and write their comments.
5. Turn in your recipe and your taster's comments at your **February 4-H meeting**.

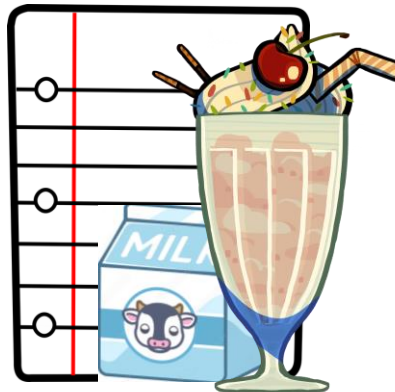

Peanut Butter Sandwich Recipe Contest Winners



Best Overall: Daisy Yareli Mr. Summerville's class; JJ Harris

Most Creative: Axel Santiago Garcia, Ms. Wynder's class; HB Stroud
& Romy Little Ms. McDevitt's class St. Joseph

Most Unusual: Riley Hughes, Ms. McWhorter's class; Barnett Shoals

Most Nutritious: Vada Lanham, Ms. McWhorter's class; Barnett Shoals



Nutrition Poster Contest Winner

Brandon Lopez Hernandez from JJ Harris

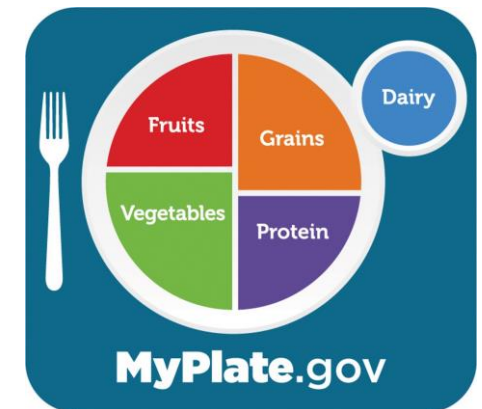



Project Fun Day! (CPA)

Saturday, February 8, 2025

ACC 4-H Cooperative Extension Facility

9:30am until Noon

Online Parent Permission Required to Attend!



- To compete in this activity, students must sign up in their classroom before January 4-H meeting or have Parent contact Ms. Conway at ebarber@uga.edu
- Students will choose a topic from the Project List, prepare an informative presentation with visuals and then present speech at ACC Extension Facility on February 8
- Winners from the CPA competition in February may compete at District Project Achievement (DPA) in Jackson County on March 22
- Only students who participate at the district competition (DPA) in March may apply for the need-based scholarships to reduce the cost of 4-H Summer Camp held at Rock Eagle in June.



Upcoming 4-H Activities



- MilkMake Recipe Contest: Recipe with Taster's Comments Due at February 4-H School Program



- County Project Achievement (CPA): Sign up with Teacher or have Parent e-mail Ms. Conway; Saturday, February 8 at 9:30am-12pm at ACC 4-H Cooperative Extension Facility ; First step in Summer Camp scholarship process



4-H Pledge

I pledge:

my HEAD to clearer thinking

my HEART to greater loyalty

my HANDS to larger service and

my HEALTH to better living

for my club, my community, my country and
my world

